

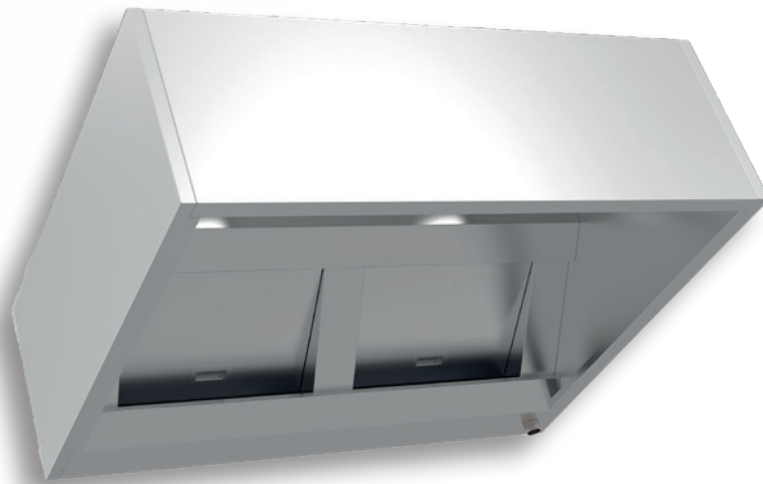

SIRH+
INNOVATION
AWARDS



BRUM'TECH

Misting hood
with recycling system



SAFE



ECO-RESPONSIBLE



SMART



VENTILATION OF PROFESSIONAL KITCHENS, A SPECIALIST AFFAIR.

BRUM'TECH

CONTEXT

| Charcoal cooking appliances are appearing in many restaurants for “eco-responsible” and “return to the origins” reasons. Such an approach entails safety risks and installation constraints in professional kitchens.

| It is therefore essential to support what restaurant owners are undertaking by offering a product that keeps their installations safe.



GENERAL PRINCIPLE

| The main function of the **BRUM'TECH** hood is to make the air extraction over solid fuel cooking appliances (charcoal oven, wood-fired grills, ...) safe.

| This type of cooking creates brands that can cause fires in the extraction network shared with other appliances. Water misting is used to put out the incandescent residues mixed with the extracted air.

| As part of an eco-responsible policy, **BRUM'TECH** has acquired a water recycling system that reduces the impact on the environment and makes savings on consumption.

| Thanks to its stand-alone operation and a user friendly interface, **BRUM'TECH** manages itself automatically while providing you all the data about the system's operation (water top-up if required, filter condition, real time consumption, etc.)

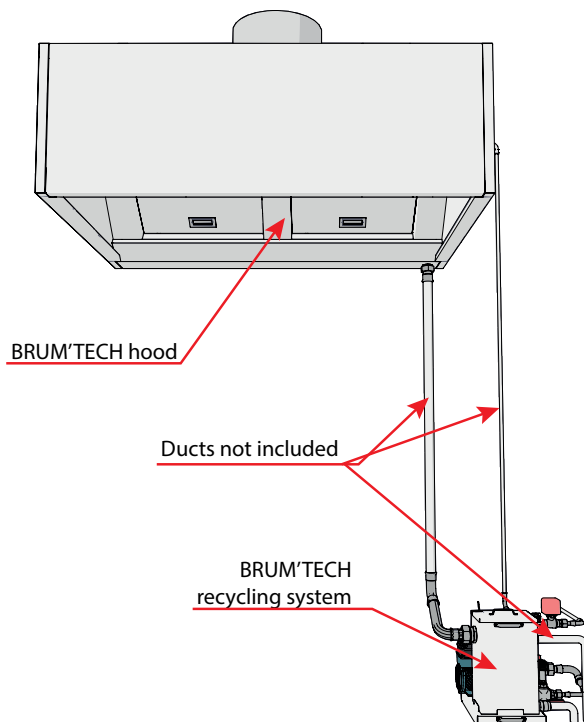

AERAILIC PRINCIPLE



safe

| The **BRUM'TECH** hood is fitted with deflector panels used to direct the air flow towards the misting bar to put out any incandescent brands. The air is then extracted through the filters into the classic duct network. The misted water and agglomerates fall into the lower part of the system.

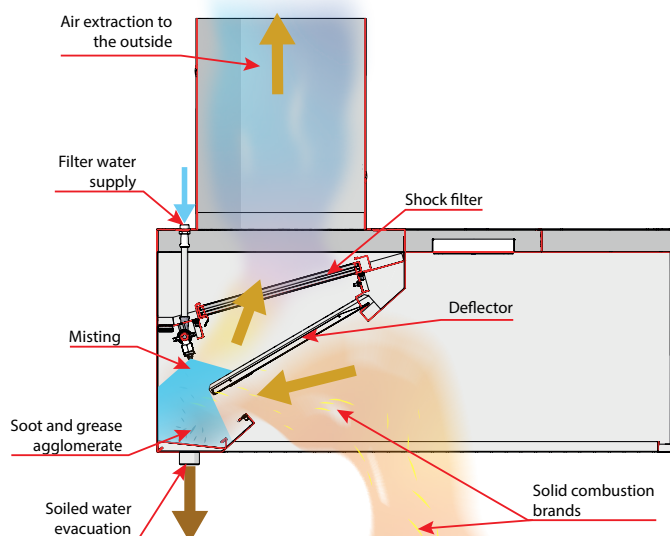

BRUM'TECH

HYDRAULIC PRINCIPLE



eco-responsible

1. The water is stored in the recycling system water tank. A filter bag filters out the soot and oil particles.
2. The filtered water coming out of the tank is extracted by an electric pump.
3. The pump then pushes the water to the misting nozzles.
4. The soiled water is collected in the lower hood collector, a pre-filtering grate traps the biggest soot particles. The water is then evacuated to the return network and back to the tank.
5. A cold water inlet is controlled by a solenoid valve for top-ups.

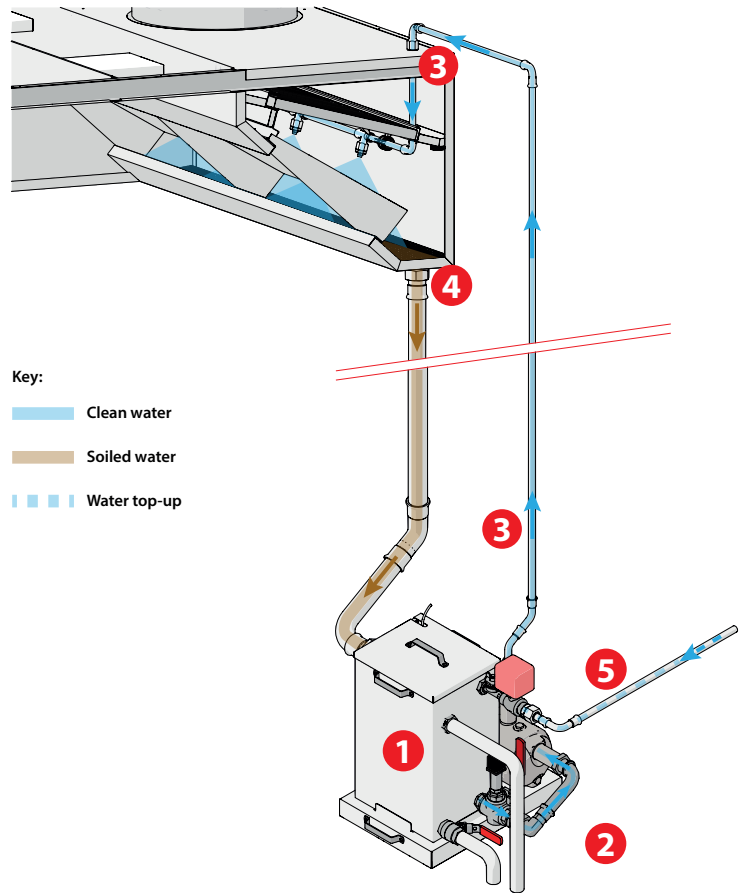

INTERFACE



smart

The interface is used to start and stop the display of the operating data for the different components.

The system mainly uses just 1 button. It is used to start and stop the misting in the hood. Once the button has been activated, the system manages itself automatically (water top-up if required, filter condition, real time consumption, etc.).

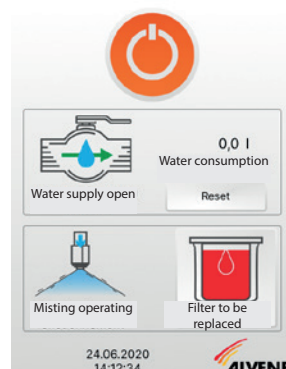
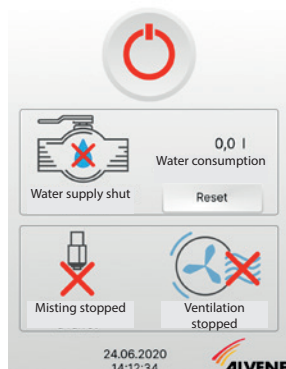
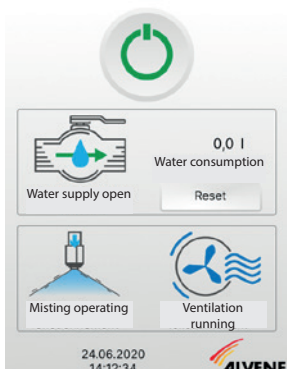

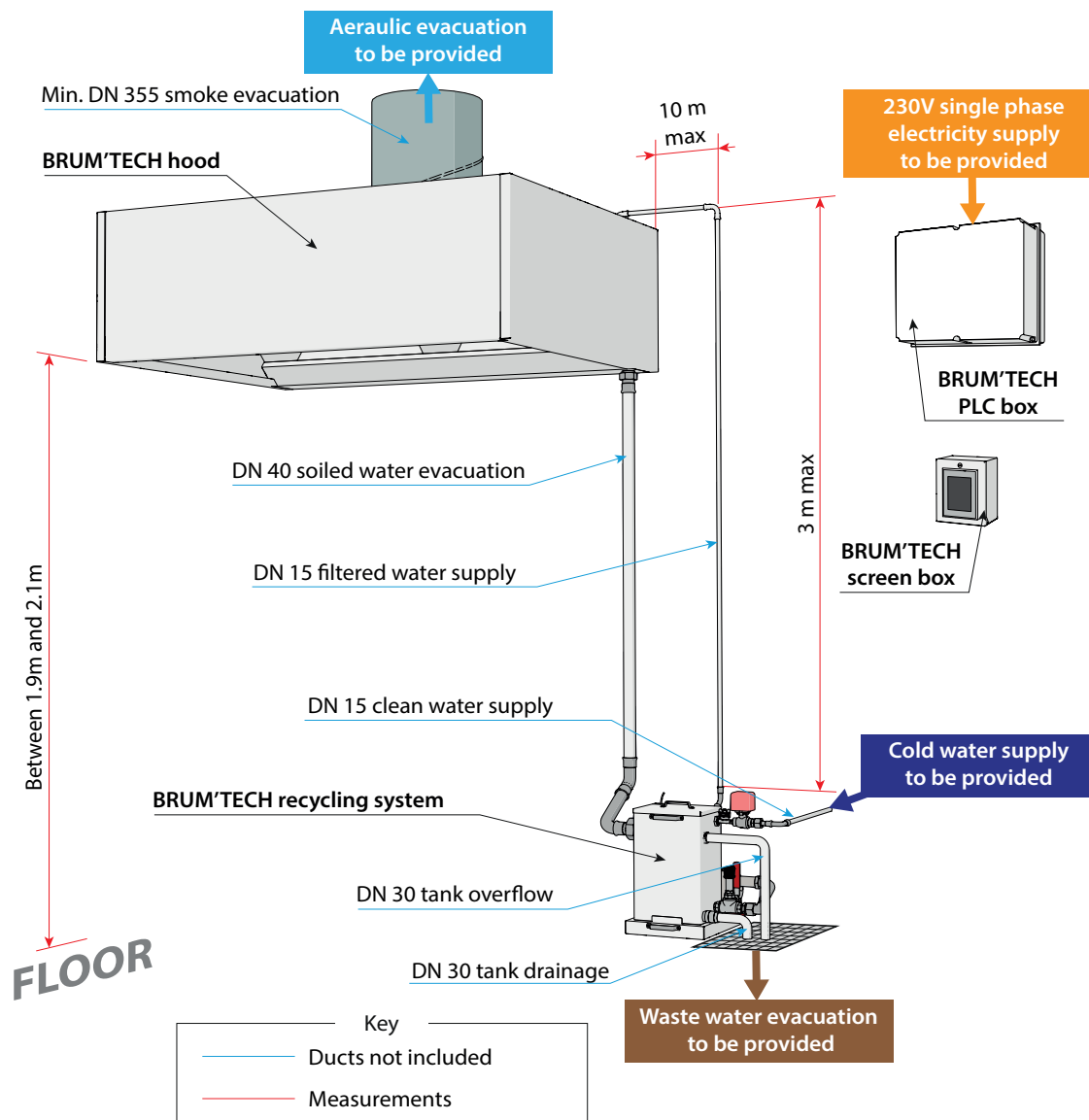

DESIGN / MANUFACTURE

| BRUM'TECH hoods are single part from 1070 to 3070.

| The hood design is based on the HEXOTECH 53 SF model (height 530mm) for the external parts.

| The join between the side gutter and the lower extractor band is welded. The extractor lower corners are welded, providing perfect leak tightness.

| The misting bar is composed of stainless steel piping and nozzles. It is designed to cover the entire volume of air passing through the extractor.

| All parts are manufactured from AISI 304 (CN 18- 10) austenitic stainless steel, brushed finish 220 grade on both sides with PVC protection.

| 398x498x25mm shock filters with stainless steel frame and handle (800³/h flow rate) are placed behind the misting bar.

HOOD DIMENSIONS

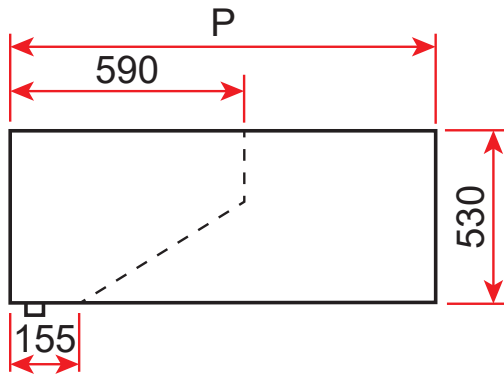

BRUM'TECH HOOD					
Model	09	11	13	15	17
P (mm)	915	1120	1240	1445	1650
Weight (kg/ml)	64	69	76	82	96

RECYCLING SYSTEM DIMENSIONS

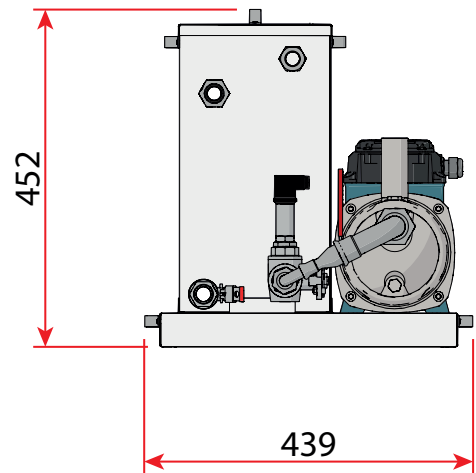
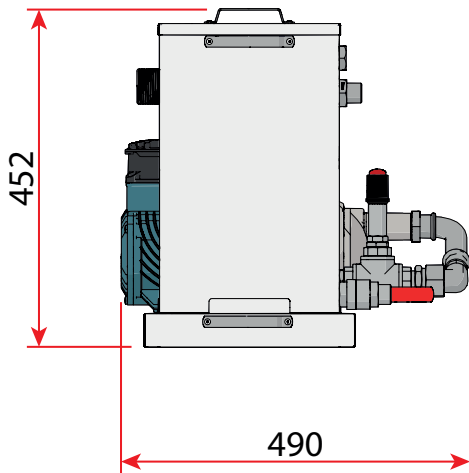

Empty recycling system weight (kg)

25kg

ELECTRIC BOX DIMENSIONS

